

CIMAN



SOMMIER

Washer Huller LE1025

Continuous or cycle operation

- Power supply 400V three-phase.
- Power 5,5KW.
- Variable speed drive with selector (hulling/draining)
- Adjustment of the output damper by hand crank

Batch operation

- Useful capacity : 0,6 m³ (400 kg of fresh nuts).
- Hulling time : 15 to 25 min.

Continuous operation

- Behind a washer
- Up to 2.5t/h

Option: motorization of the outlet register

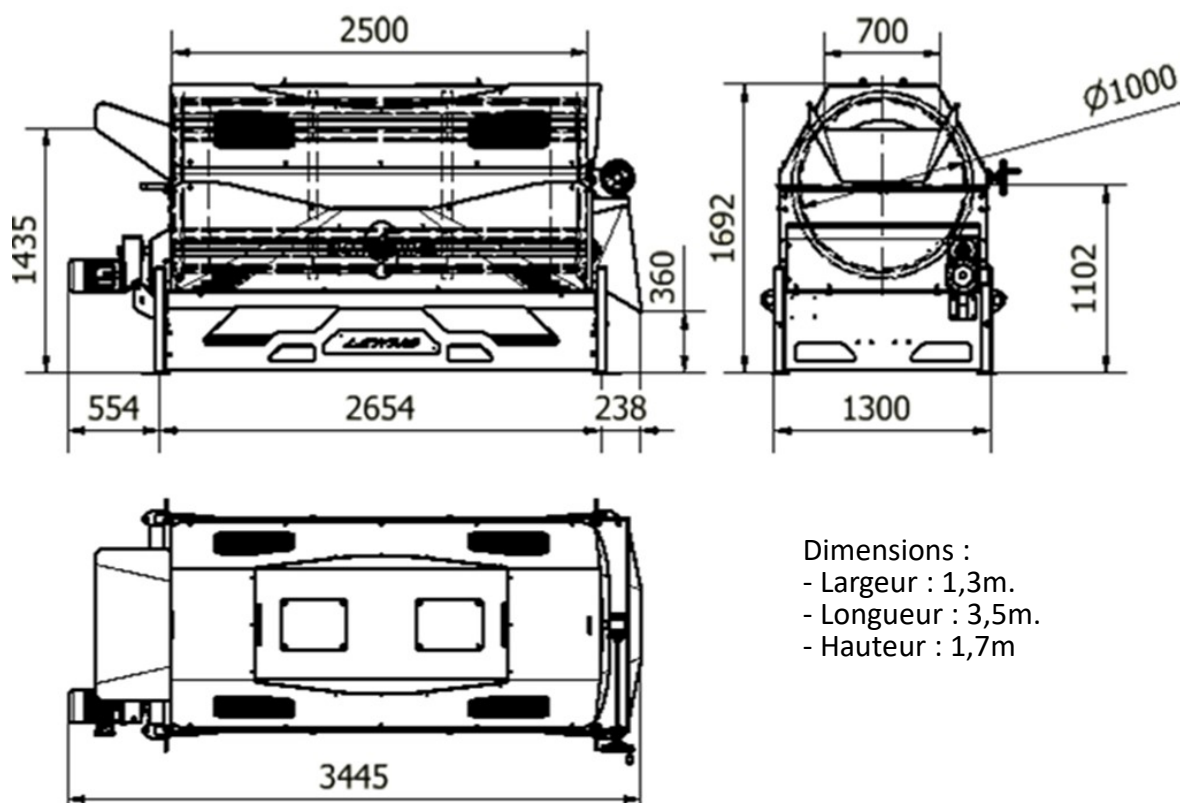

Sarl CIMAN - 19240 ALLASSAC - Phone 33 (0)5 55 22 64 49
www.sommier.biz - Email : info@sommier.biz